

## SpeedThru to ERC Timer

LMA-200 or LMA-1250 vehicle detector

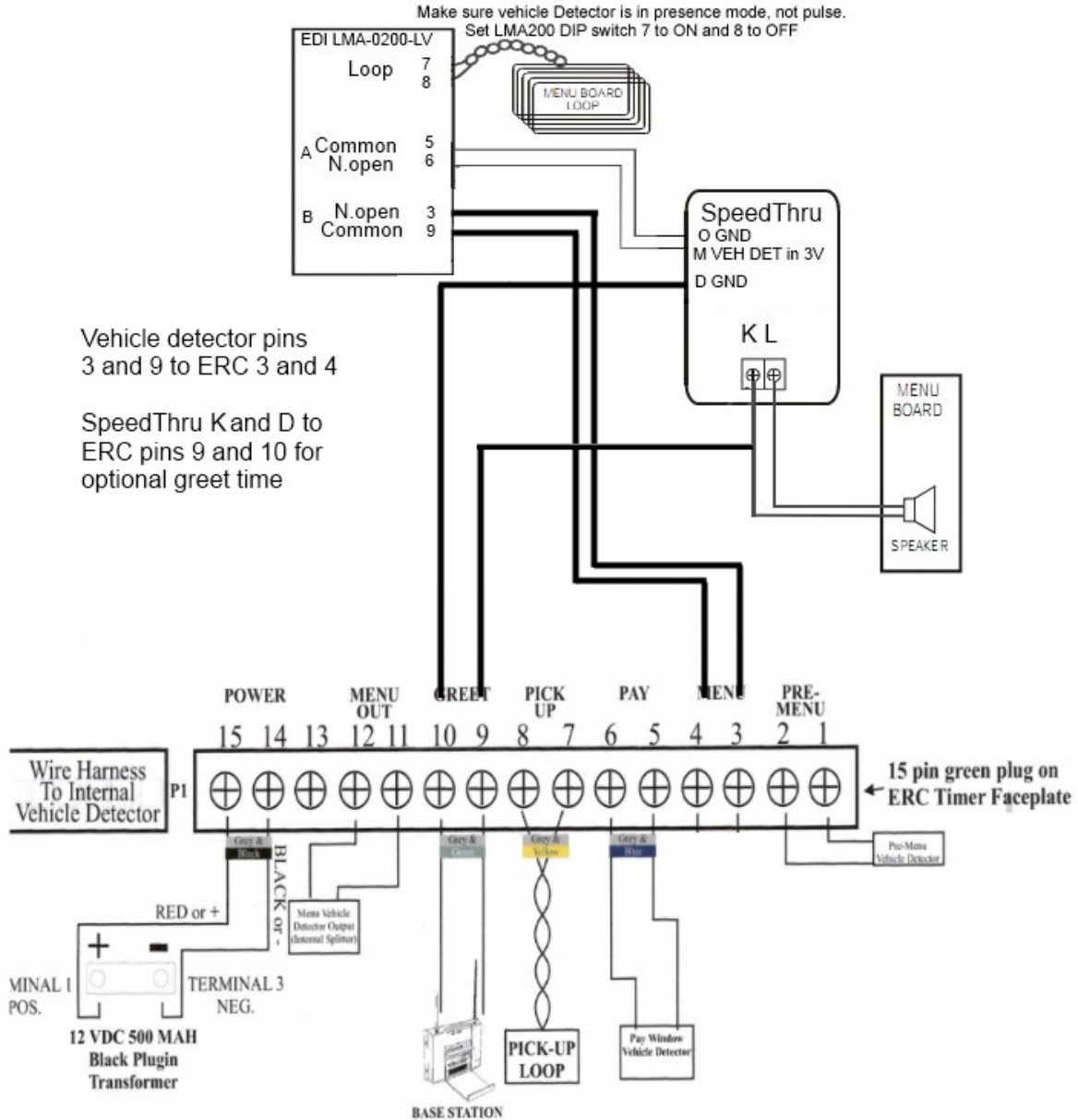

Make sure all wire to wire connections are soldered. Do not use wire nuts.

All wire ends connected to terminal blocks must be tinned.

1. Make sure vehicle detect is in presence mode.
2. Make sure vehicle detector output B mode is set to duplicate output A.
3. Refer to Wentworth's technical support website for vehicle detector dip switch settings as the settings are different for the LMA-200 and LMA-1250.